

TPHK Series

Immersible Pump



Contents

General Data	2
Performance Range	3
Sectional Drawing	4
Performance Curves/Technical Data	
TPHK 2T	5
TPHK 4T	7
TPHK 8T	9
TPHK 12T	11

TPHK Series Immersible Pump



50Hz

Power: 0.34 - 3.8 kW

Head: Up to 65M

Flow: Up to 280 L/min

60Hz

Power: 0.37 - 4.15 kW

Head: Up to 90M

Flow: Up to 280 L/min

Outlet: 3/4" - 1 1/4"

Applications

The TPHK Series is vertical multistage centrifugal pump, designed for industrial use, specially for machine tools. It is suitable to carry fluids such as water, coolant, light oil and other clean, non aggressive matters:

- Industrial circulation system
- Washing/cleaning system
- Filtration system

Operating Conditions

1. Ambient temperature : Max. +40°C
2. Liquid temperature range : +0°C ~ +90°C
3. Operating pressure : Max. 10 kg/cm²
4. Submerged depth : Min. 40mm

Model code

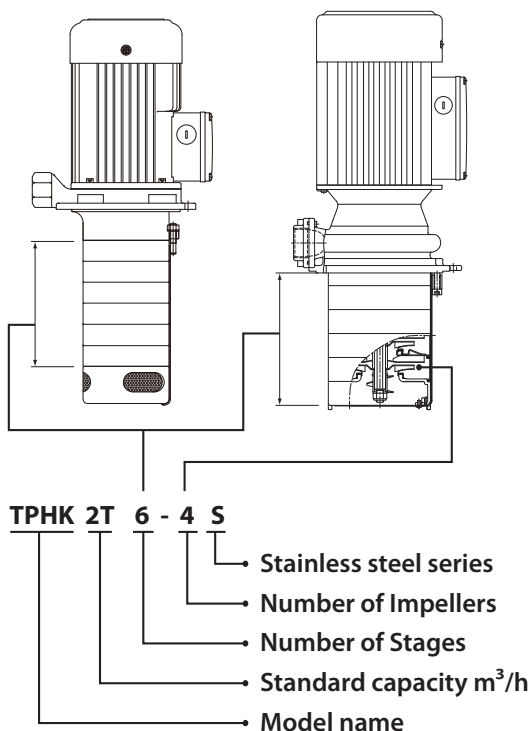

Pump Construction

Immersible vertical multistage centrifugal pump, self-priming, co-axial pump/motor design, impellers mounted on extended motor shaft. Main working parts made by stainless steel.

Motor

Enclosure class : IP54

Insulation class : F.

Nominal speed : 2900 / 3500 rpm

Frequency range : 50 / 60 Hz

Voltages Code :

Code	PH	50Hz	60Hz
53Q	3	200-240/380-440V	-
A3Z*	3	200-255/380-440V	200-255/380-480V
A3U*	3	200-240/380-415V	200-240/380-440V

* The motor can be use in both 50/60 hz.

TPHK Series Immersible Pump

Performance curve (50Hz)

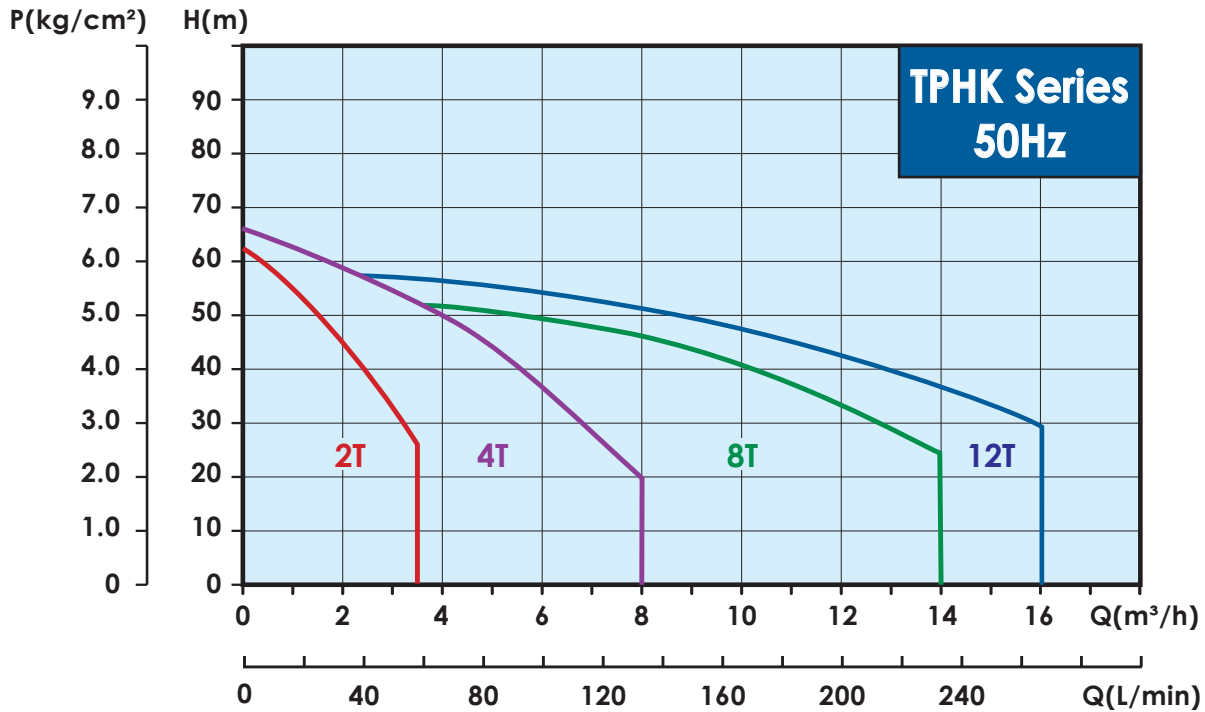

Performance curve (60Hz)

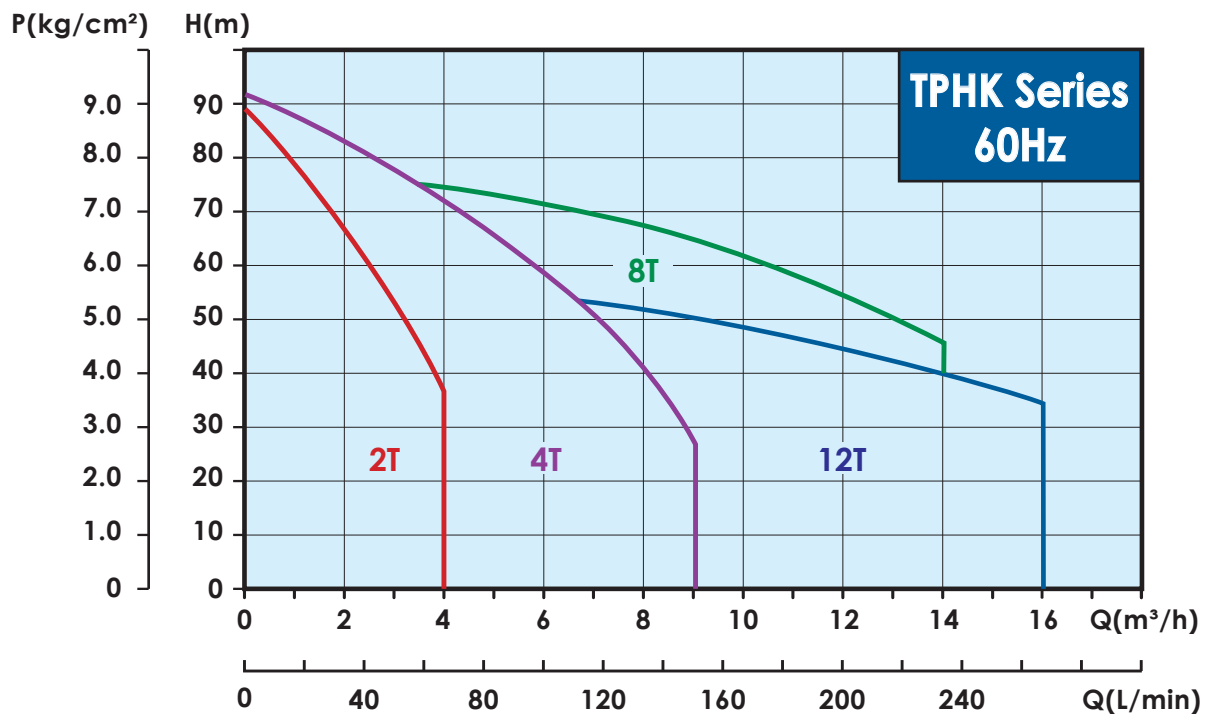

Sectional drawing

TPHK 2T/4T

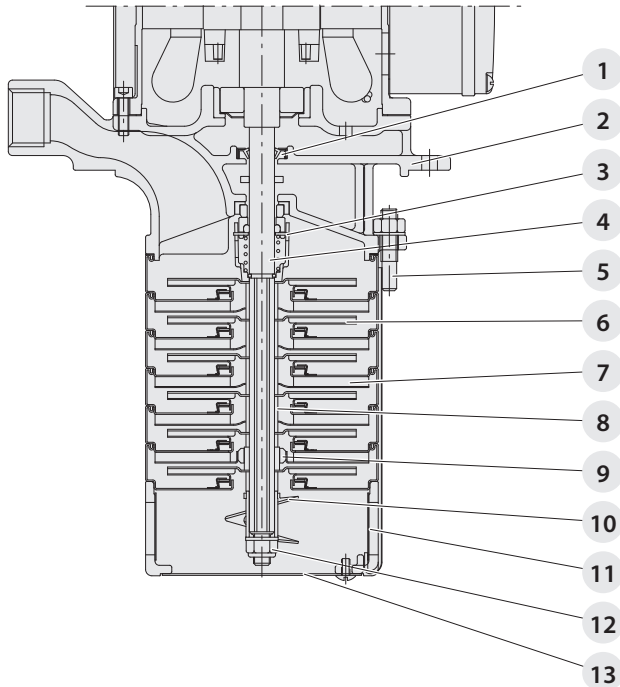

Materials

NO.	Part name	Material	
		Standard	S series
1	Oil Seal	NBR	
2	Pump Casing	FCD 45	SUS 304
3	Mechanical Seal	HSSH	HGSH
4	Shaft	SUS 304	
5	Strap	SUS 304	
6	Impeller	SUS 304	
7	Intermediate chamber	SUS 304	
8	Sleeve	SUS 304	
9	Bearing	SiC	
10	Priming screw	SUS 304	
11	Suction interconnector	SUS 304	
12	Lock Nut	SUS 316	
13	Filter	SUS 304	
14	Flange	SUS 304	

TPHK 8T/12T

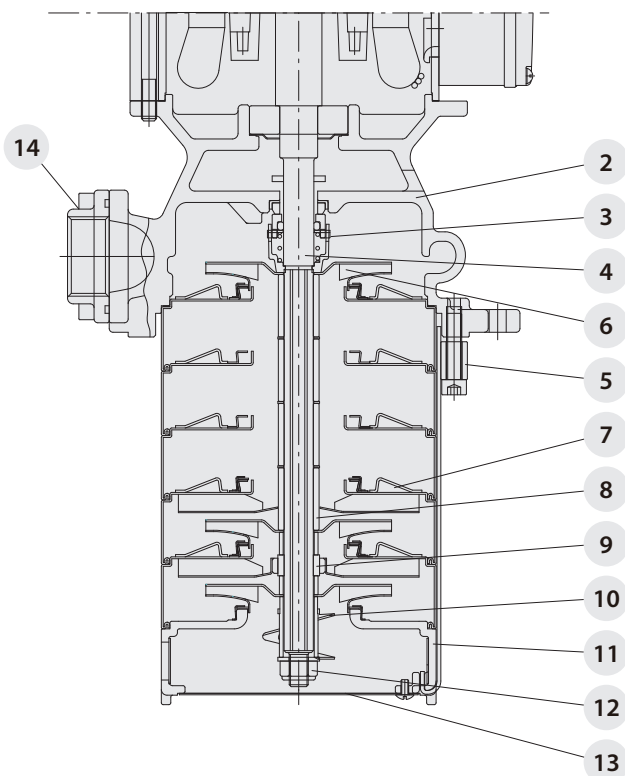

Options on request

- Special mechanical seal

Mechanical seal type	Material	
	Stationary Face/ Rotary Face	Cup Gasket & O Ring
HGSH HGSV HGSE	(G)Carbon/ (S)Silicium carbide	(H) HNBR (V) Viton
HSSH HSSV HSSE	(S)Silicium carbide/ (S)Silicium carbide	(E) EPDM

TPHK 2T

Electrical data

Standard Model	Phase (Ø)	Voltage code	Cycle (Hz)	Volts (V)	Input Power (W)	Input Power (A)
TPHK 2T 3 - 1	3	A3Z	50	200-255 / 380-440	340	1.6-2.8 / 1.0-1.5
			60	200-255 / 380-480	370	1.5-1.9 / 1.0-1.3
TPHK 2T 3 - 2	3	A3Z	50	200-255 / 380-440	450	1.9-2.8 / 1.2-1.5
			60	200-255 / 380-480	560	2.1-2.2 / 1.5-1.5
TPHK 2T 3 - 3	3	A3Z	50	200-255 / 380-440	530	2.0-2.8 / 1.3-1.6
			60	200-255 / 380-480	750	2.6-2.5 / 1.6-1.6
TPHK 2T 4 - 4	3	A3Z	50	200-255 / 380-440	620	2.2-2.9 / 1.4-1.7
			60	200-255 / 380-480	910	3.0-2.9 / 1.7-1.7
TPHK 2T 5 - 5	3	A3Z	50	200-255 / 380-440	700	2.4-3.0 / 1.4-1.6
			60	200-255 / 380-480	1060	3.3-3.0 / 1.8-1.8
TPHK 2T 6 - 6	3	A3Z	50	200-255 / 380-440	850	3.1-3.6 / 1.8-2.1
			60	200-255 / 380-480	1290	4.0-3.6 / 2.4-2.4
TPHK 2T 7 - 7	3	A3U	50	200-240 / 380-415	1320	4.6-6.7 / 2.9-3.7
			60	200-240 / 380-440	1800	5.6-5.4 / 3.2-3.2

Maximum 11 Stages

Dimensions (mm)

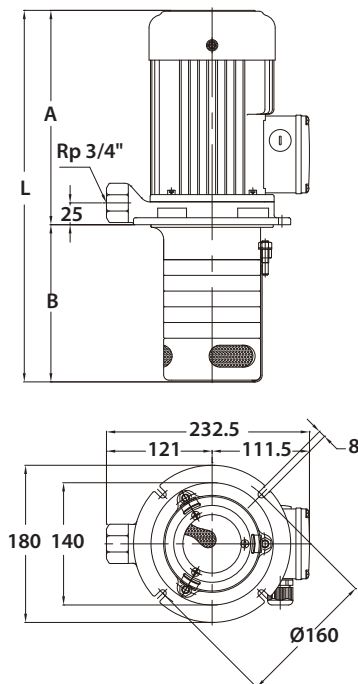

Model	A (mm)	B (mm)	L (mm)	N.W.(kg)	
TPHK 2T 3 - 1	205.5	144	349.5	10.9	30
TPHK 2T 8 - 1	205.5	234	439.5	11.9	30
TPHK 2T 3 - 2	205.5	144	349.5	11.1	30
TPHK 2T 5 - 2	205.5	180	385.5	11.5	30
TPHK 2T 9 - 2	205.5	252	457.5	12.3	30
TPHK 2T 3 - 3	205.5	144	349.5	11.2	30
TPHK 2T 4 - 3	205.5	162	367.5	11.4	30
TPHK 2T 5 - 3	205.5	180	385.5	11.6	30
TPHK 2T 6 - 3	205.5	198	403.5	11.8	30
TPHK 2T 8 - 3	205.5	234	439.5	12.2	30
TPHK 2T11-3	205.5	288	493.5	12.6	24
TPHK 2T 4 - 4	205.5	162	367.5	11.5	30
TPHK 2T 6 - 4	205.5	198	403.5	11.9	30
TPHK 2T 5 - 5	245.5	180	425.5	12.7	30
TPHK 2T 6 - 5	245.5	198	443.5	13.3	30
TPHK 2T 6 - 6	253.5	198	451.5	13.5	30
TPHK 2T 8 - 6	253.5	234	487.5	13.9	30
TPHK 2T 9 - 6	253.5	252	505.5	14.1	24
TPHK 2T10-6	253.5	270	523.5	14.2	24
TPHK 2T11-6	253.5	288	541.5	14.4	24
TPHK 2T 7 - 7	253.5	216	469.5	13.0	30

Performance curve (50Hz)

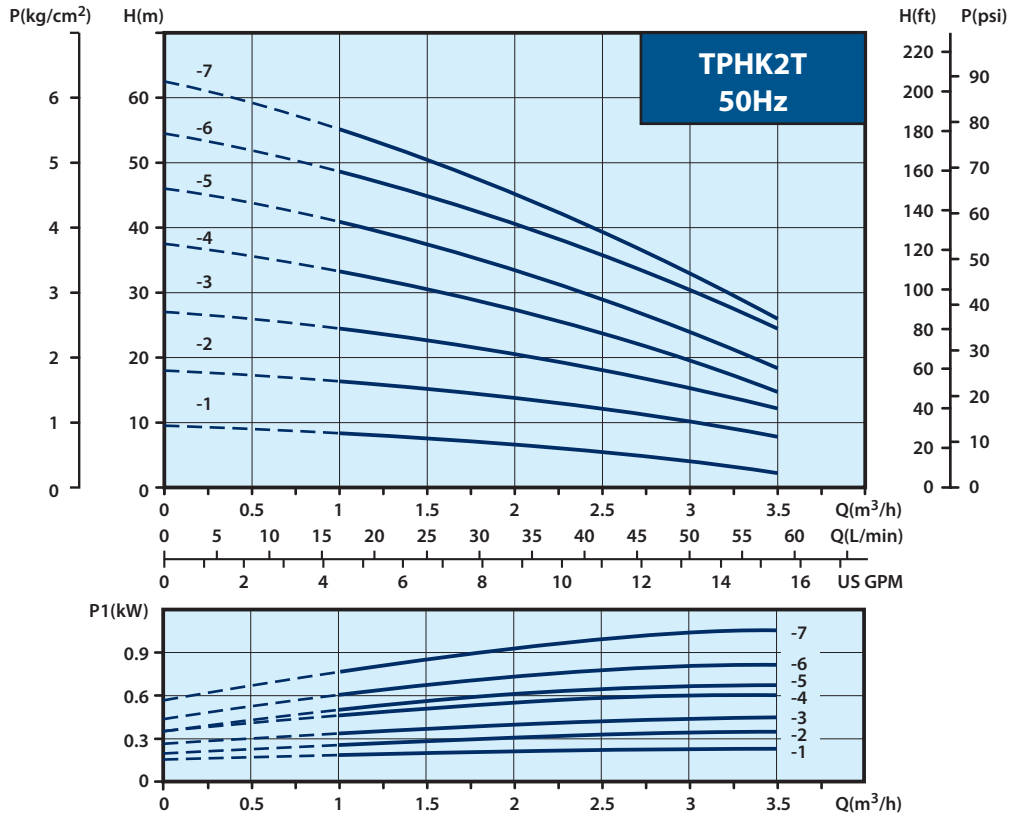

Performance curve (60Hz)

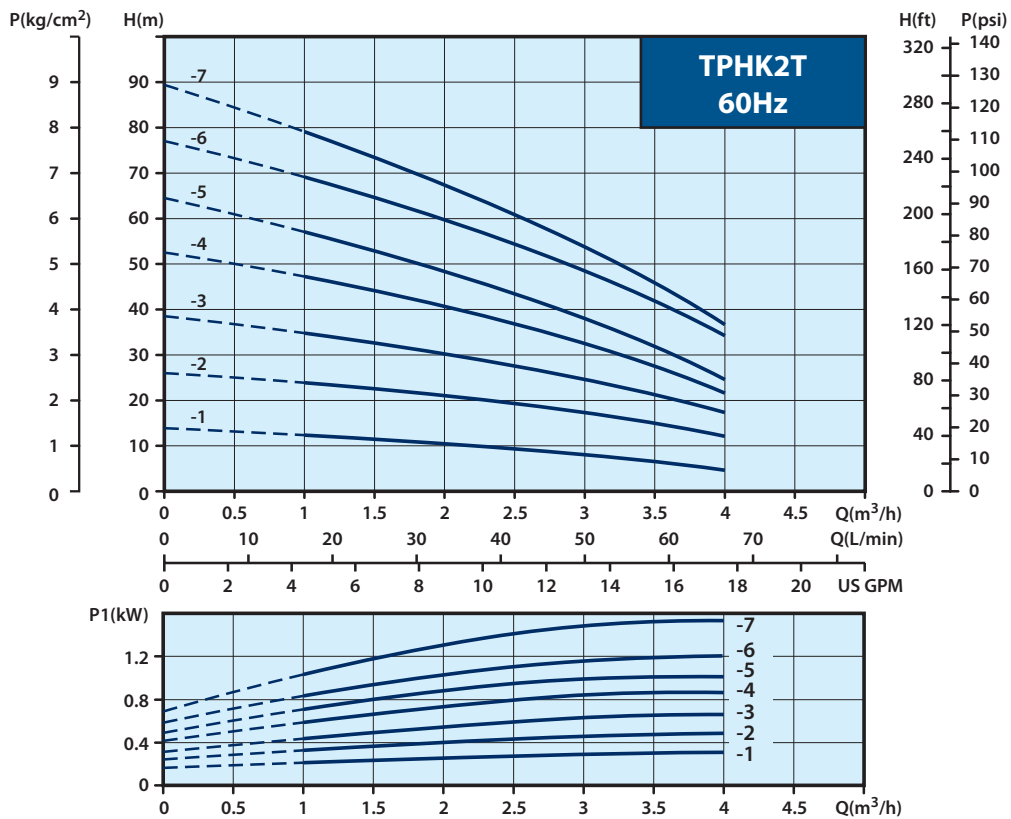

TPHK 4T

Electrical data

Standard Model	Phase (Ø)	Voltage code	Cycle (Hz)	Volts (V)	Input Power (W)	Input Ampere (A)
TPHK 4T 2 - 1	3	A3Z	50	200-255 / 380-440	570	1.9-2.8 / 1.2-1.7
			60	200-255 / 380-480	600	2.3-2.3 / 1.4-1.4
TPHK 4T 2 - 2	3	A3Z	50	200-255 / 380-440	650	2.2-2.9 / 1.4-1.7
			60	200-255 / 380-480	960	3.0-2.7 / 1.7-1.7
TPHK 4T 3 - 3	3	A3Z	50	200-255 / 380-440	850	3.1-3.6 / 1.8-2.1
			60	200-255 / 380-480	1290	4.0-3.6 / 2.4-2.4
TPHK 4T 4 - 4	3	A3U	50	200-240 / 380-415	1080	3.4-3.5 / 2.0-2.0
			60	200-240 / 380-440	1620	4.5-5.0 / 2.9-2.9
TPHK 4T 5 - 5	3	A3U	50	200-240 / 380-415	1440	4.9-6.8 / 3.0-3.8
			60	200-240 / 380-440	2100	6.2-6.0 / 3.5-3.5
TPHK 4T 6 - 6	3	A3U	50	200-240 / 380-415	1740	6.3-9.9 / 4.2-5.5
			60	200-240 / 380-440	2400	7.7-7.6 / 4.5-4.5
TPHK 4T 7 - 7	3	A3U	50	200-240 / 380-415	2140	6.9-10.3 / 4.5-5.8
			60	200-240 / 380-440	2800	8.7-8.4 / 4.9-4.9

Maximum 8 Stages

Dimensions (mm)

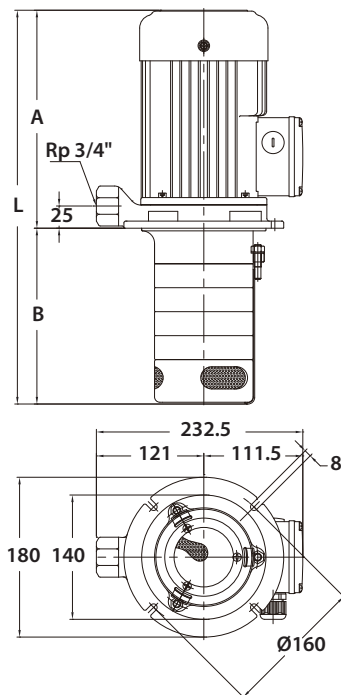

Model	A (mm) 50Hz / 60Hz	B (mm)	L (mm) 50Hz / 60Hz	N.W.(kg)	
TPHK 4T 2 - 1	205.5	144	349.5	10.8	30
TPHK 4T 3 - 1	205.5	171	376.5	11.0	30
TPHK 4T 2 - 2	205.5	144	349.5	11.0	30
TPHK 4T 3 - 2	205.5	171	376.5	11.2	30
TPHK 4T 4 - 2	205.5	198	403.5	11.4	30
TPHK 4T 6 - 2	205.5	252	457.5	11.6	24
TPHK 4T 3 - 3	245.5	171	416.5	11.7	30
TPHK 4T 4 - 3	245.5	198	443.5	11.9	30
TPHK 4T 5 - 3	245.5	225	470.5	12.1	30
TPHK 4T 6 - 3	245.5	252	497.5	12.3	24
TPHK 4T 8 - 3	245.5	306	551.5	12.7	24
TPHK 4T 4 - 4	245.5	198	443.5	13.3	30
TPHK 4T 5 - 4	245.5	225	470.5	13.5	30
TPHK 4T 6 - 4	245.5	252	497.5	13.7	24
TPHK 4T 5 - 5	245.5	225	470.5	13.9	30
TPHK 4T 8 - 5	245.5	306	551.5	14.5	24
TPHK 4T 6 - 6	253 / 284.5	252	506 / 536.5	14.1	24
TPHK 4T 8 - 6	253 / 284.5	306	560 / 590.5	14.6	24
TPHK 4T 7 - 7	284.5	279	563.5	14.6	24
TPHK 4T 8 - 7	284.5	306	590.5	14.8	24

Performance curve (50Hz)

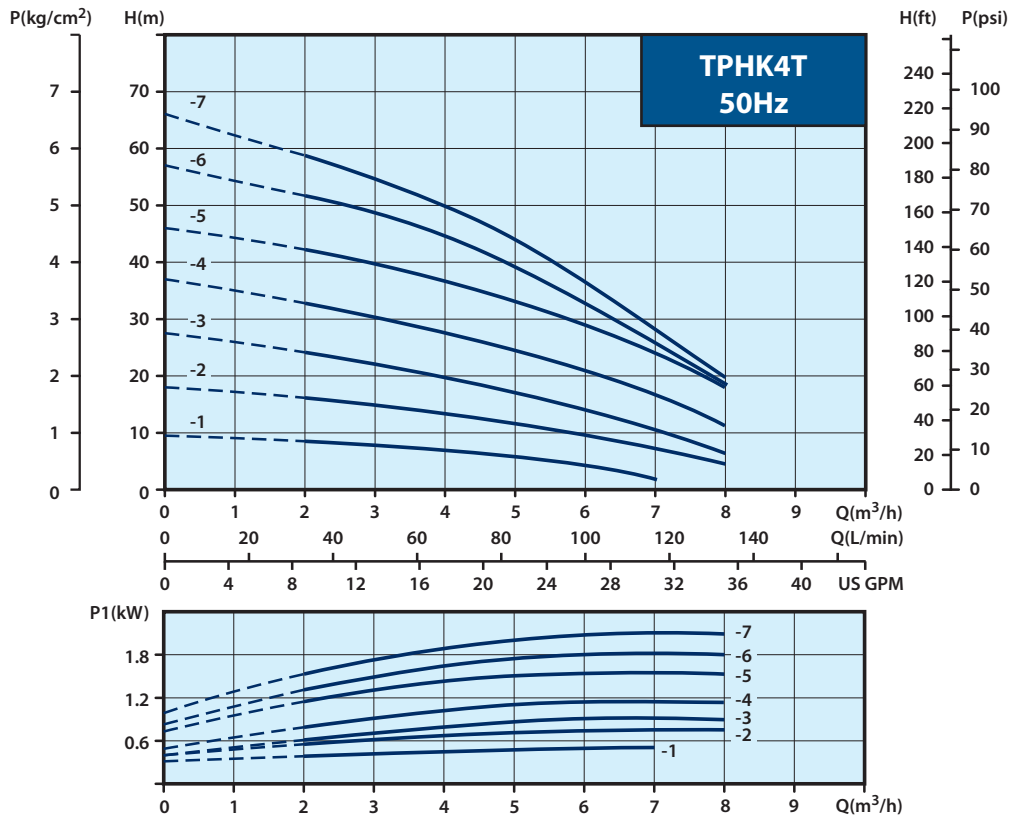

Performance curve (60Hz)

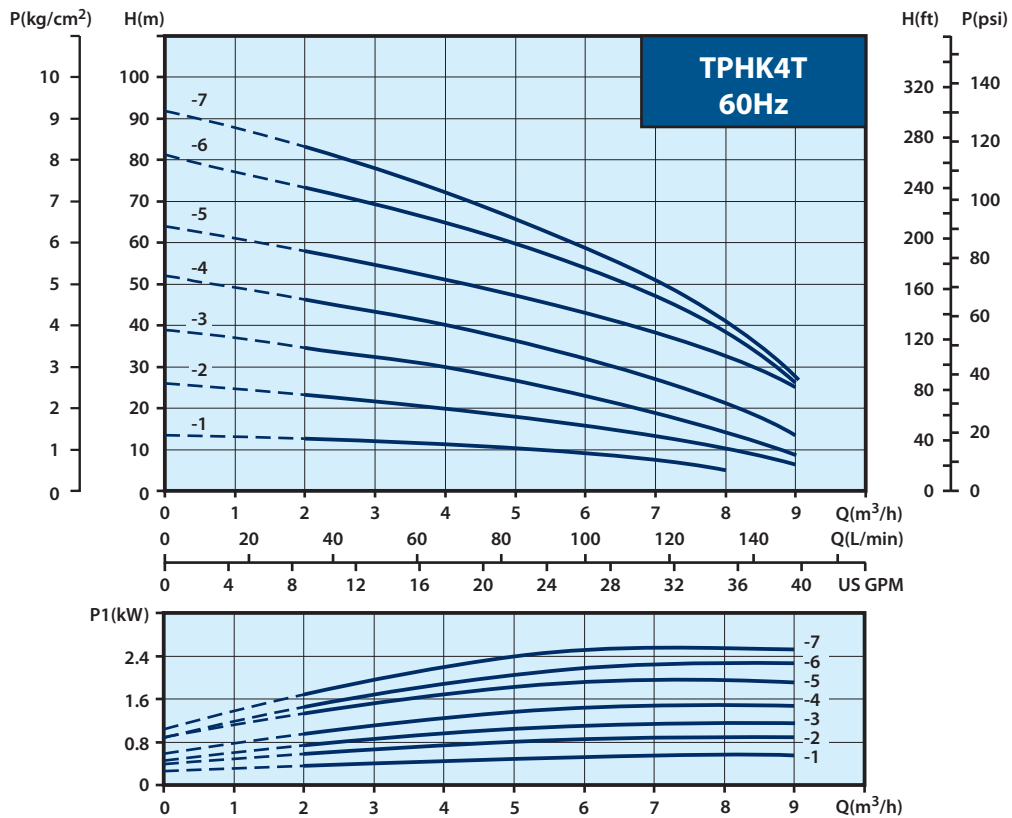

TPHK 8T

Electrical data

Standard Model	Phase (Ø)	Voltage code	Cycle (Hz)	Volts (V)	Input Power (W)	Input Ampere (A)
TPHK 8T 6 - 2	3	A3Z	50	200-255 / 380-440	1200	3.7-6.0 / 2.3-3.2
			60	200-255 / 380-480	1650	5.1-4.7 / 2.8-2.9
TPHK 8T 3 - 3	3	A3Z	50	200-255 / 380-440	1550	4.9-6.3 / 2.9-3.6
			60	200-255 / 380-480	2350	7.1-6.4 / 4.0-3.7
TPHK 8T 4 - 4	3	A3U	50	200-240 / 380-415	2200	7.6-13.2 / 5.7-8.0
			60	200-240 / 380-440	3000	9.3-9.6 / 5.3-5.7
TPHK 8T 5 - 5	3	A3U	50	200-240 / 380-415	2600	8.5-13.5 / 5.7-7.9
			60	200-240 / 380-440	3900	11.4-12.3 / 6.3-6.5

Maximum 9 Stages

Dimensions (mm)

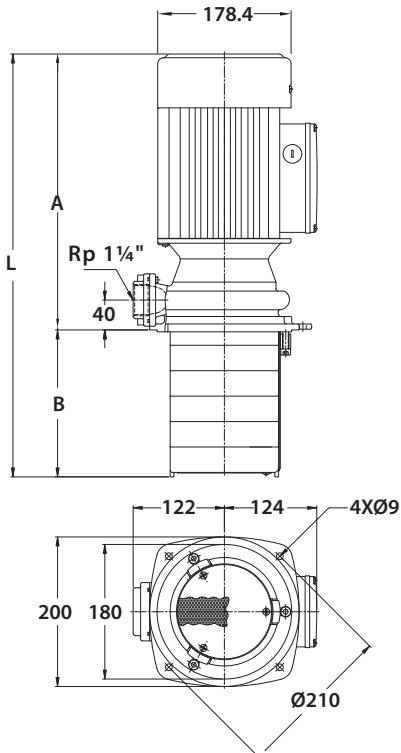

Model	A (mm)	B (mm)	L (mm)	N.W.(kg)	
TPHK 8T 6 - 2	369	196.5	565.5	24.0	15
TPHK 8T 9 - 2	369	298.5	667.5	25.3	15
TPHK 8T 3 - 3	369	94.5	463.5	23.0	15
TPHK 8T 6 - 3	369	196.5	565.5	24.3	15
TPHK 8T 9 - 3	369	298.5	667.5	25.6	15
TPHK 8T 4 - 4	369	128.5	497.5	27.0	15
TPHK 8T 6 - 4	369	196.5	565.5	28.0	15
TPHK 8T 5 - 5	369	162.5	531.5	28.0	15

Performance curve (50Hz)

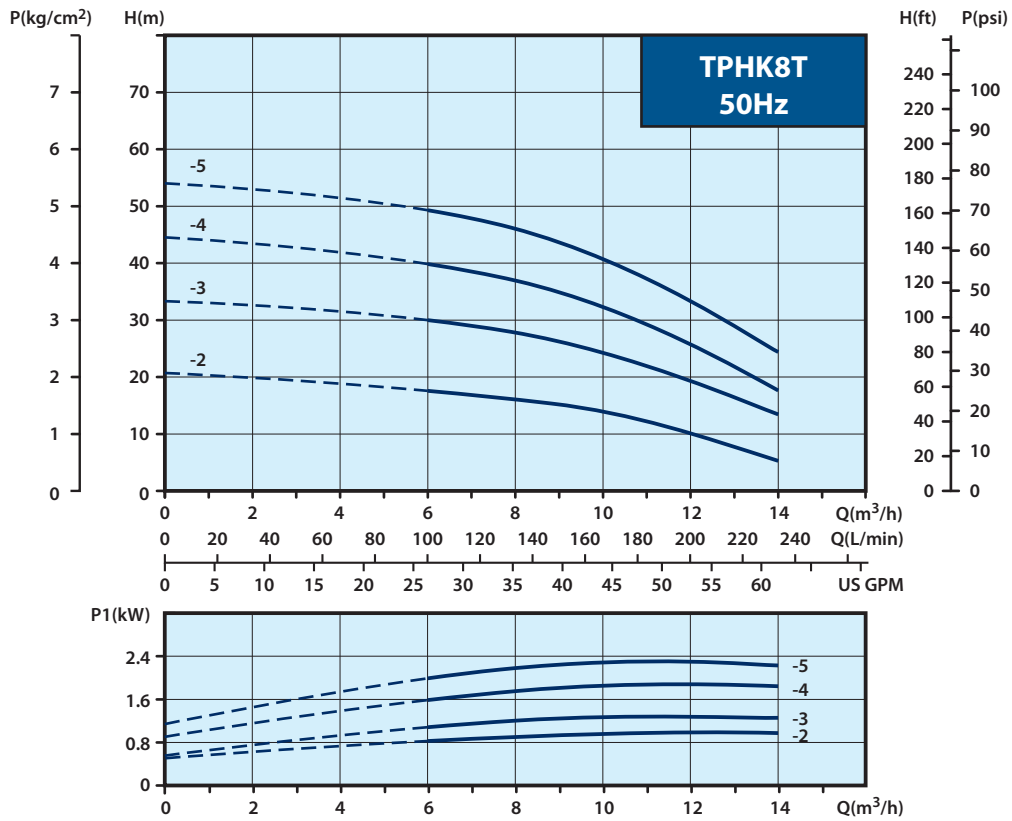

Performance curve (60Hz)

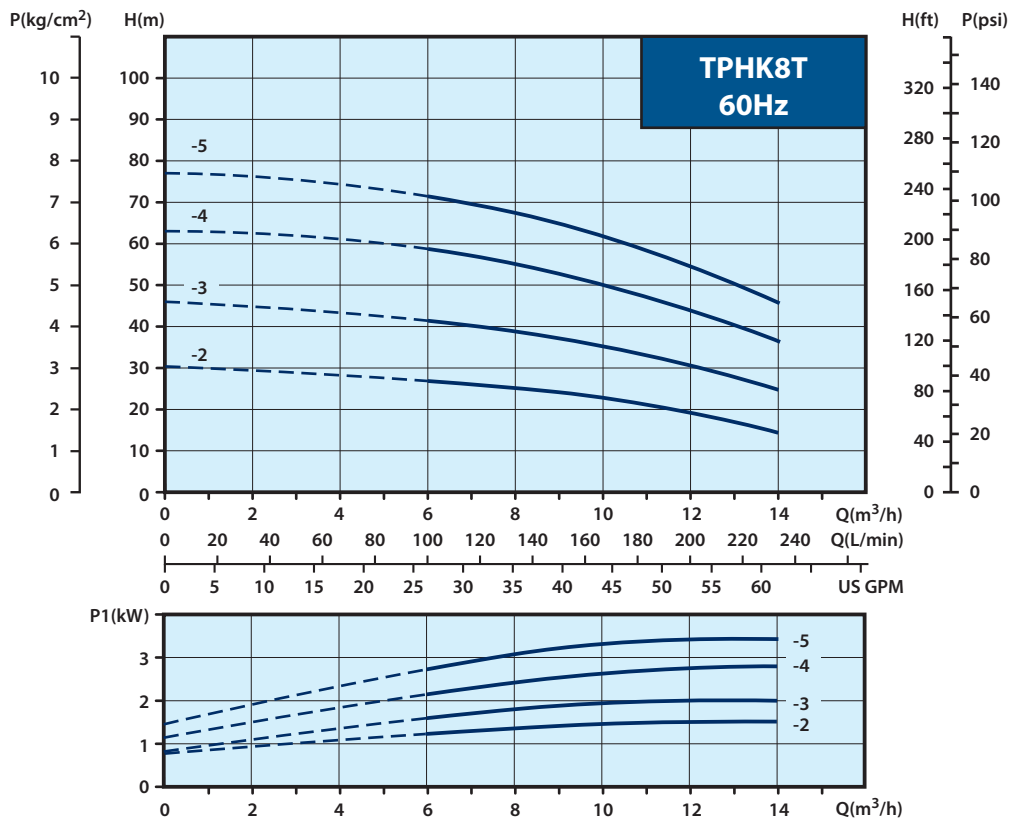

TPHK 12T

Electrical data

Standard Model	Phase (Ø)	Voltage code	Cycle (Hz)	Volts (V)	Input Power (W)	Input Ampere (A)
TPHK 12T 6 - 1	3	A3Z	50	200-255 / 380-440	1400	4.5-6.3 / 2.7-3.4
			60	200-255 / 380-480	2000	6.6-5.8 / 3.6-2.9
TPHK 12T 6 - 2	3	A3U	50	200-240 / 380-415	3120	9.6-13.9 / 6.4-8.4
			60	200-240 / 380-440	4150	12.8-12.4 / 7.1-7.4
TPHK 12T 6 - 3	3	53Q	50	200-240 / 380-440	3830	11.6-11.5 / 6.5-7.2

Maximum 9 Stages

Dimensions (mm)

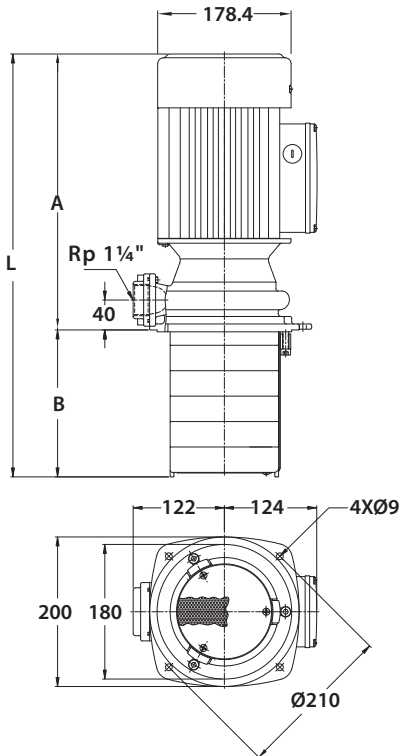

Model	A (mm)	B (mm)	L (mm)	N.W.(kg)	
TPHK12T 6 - 1	369	196.5	565.5	27.0	15
TPHK12T 6 - 2	369	196.5	565.5	29.0	15
TPHK12T 9 - 2	369	298.5	667.5	30.5	15
TPHK12T 6 - 3	369	196.5	565.5	30.0	15
TPHK12T 9 - 3	369	298.5	667.5	31.5	15

Performance curve (50Hz)

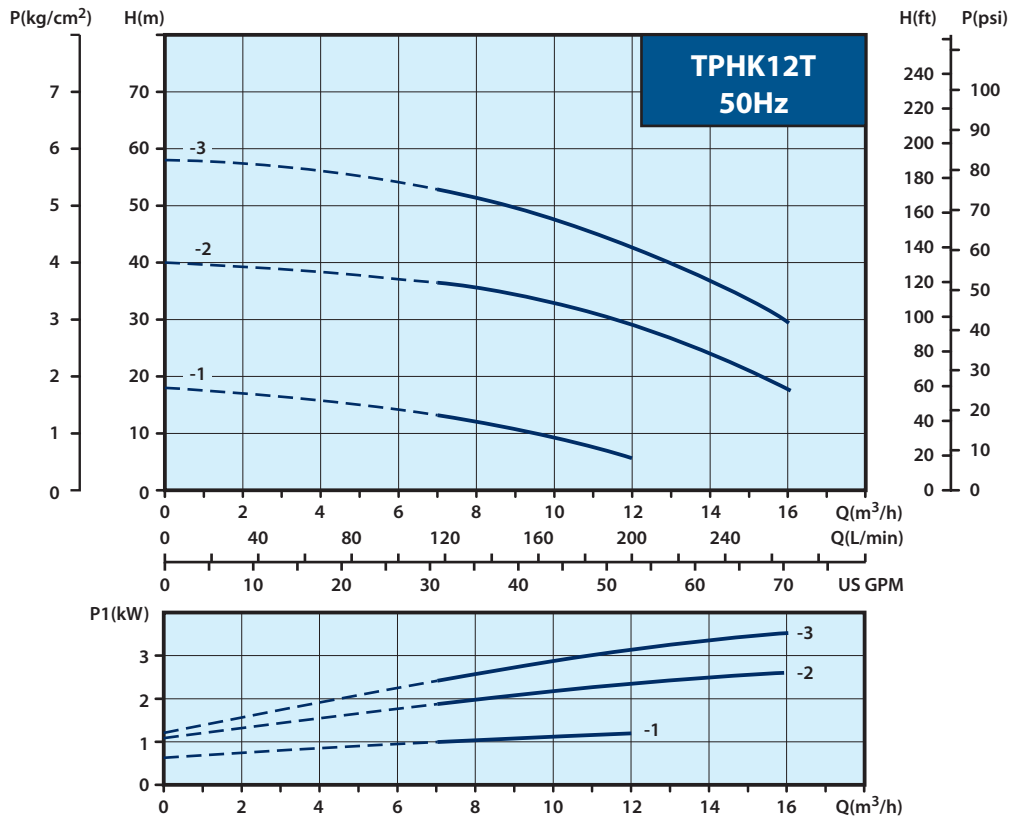

Performance curve (60Hz)

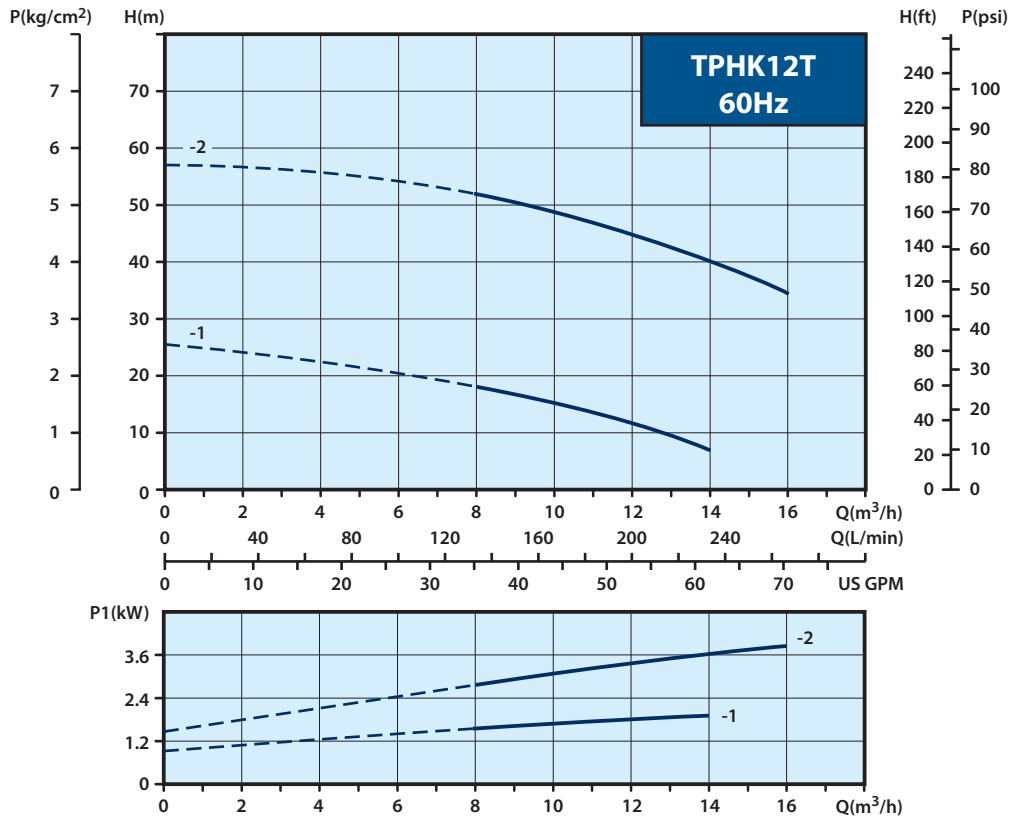



WALRUS
www.walruspump.com

OILSERVE

Oilserve Co., Ltd.
9 Soi Thawi Watthana 25 Yeak 7
Thawi Watthana, Thawi Watthana, Bangkok 10170

www.oilservethai.com
Tel : 02 441 9247 Fax : 02 441 9248
E-mail : oilserveco@gmail.com, sales@oilservethai.com